

Earth-Rite[®] PLUS[™]

Technical Specification and Certification Data

Mechanical Installation Data

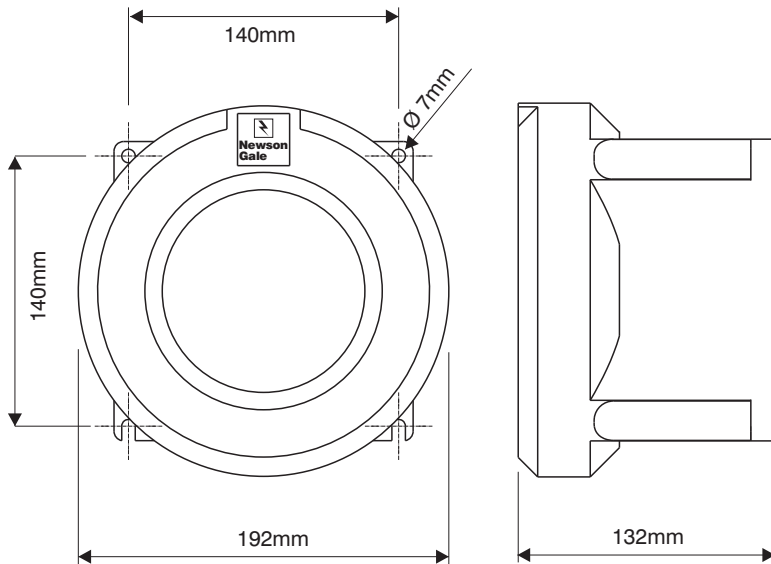

ATEX certified / UL Approved copper free cast aluminium enclosure - IP 66 / NEMA 4X, 7 & 9

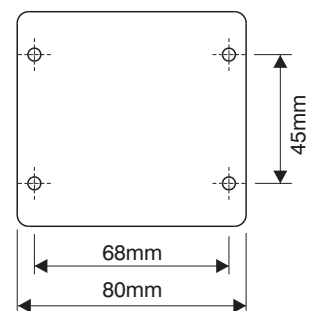
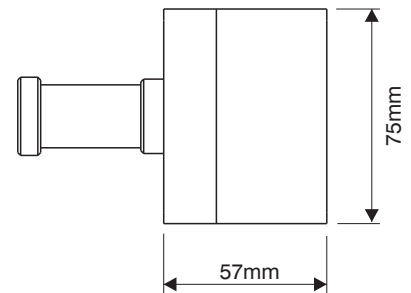

Simple Apparatus GRP clamp storage box with grounding clamp storage pin

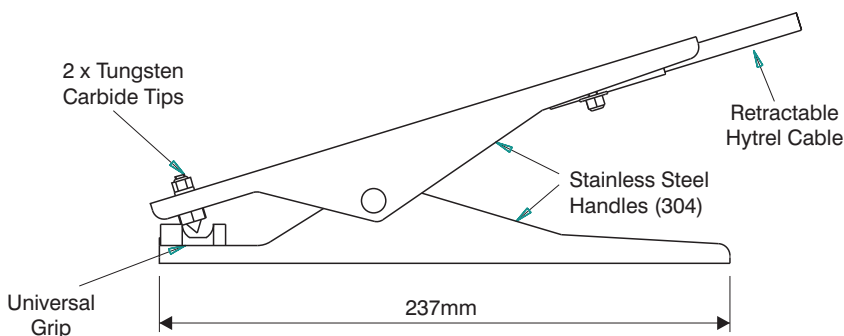

ATEX certified / FM Approved 2 Pole stainless steel grounding clamp fitted with one pair of tungsten carbide tips



IECEx SIL 2

Electrical and Certification Data

Monitoring Unit

Power Supply	110/120V or 220/240V AC, 50-60 Hz
Power Rating	10 watt
Ambient Temperature Range	-40°C to +55°C
Ingress Protection	IP 66
Weight	4.5 kgs (9.9 lbs) nett
Construction	Copper-free cast aluminium
Certification	Ex d[jia] IIC T6 Gb(Ga) Ex tb IIIC T80°C IP66 Db Ta= -40°C to +55°C
Monitoring Circuit	Intrinsically Safe
Operational Series Ground Resistance	Nominally <10 Ohm
Output Relay Contact Rating	2 off voltage free change-over switch contacts, 250Vac, 5A, 500VA max resistive
Cable Entries	7 x M20 (2 x plugged)

Junction Box/Stowage Point

Enclosure Material	GRP with carbon loading
Terminals	2 x 2.5mm sq conductor capacity
Stowage Device	Insulated 20mm Ø pin
Cable Entries	1 x 20mm
Clamp Cable Connection	Quick Connect

Grounding Clamp

Clamp Design	2 pole with tungsten carbide contacts
Body	Stainless steel

Spiral Cable

Cable	Blue Cen-Stat Hytrel sheath (Static dissipative, chemical & abrasion resistant)
Conductors	2 x 1.00mm sq copper
Length	10 metres extended, 1 metre unextended (other options available)

Ordering Code	Product Description
PLUSMEA1A3*	Earth-Rite PLUS™ Static Grounding Unit - ATEX IIC, 220/240Vac ±10% including Heavy Duty grounding clamp, 10m retractable spiral cable and GRP clamp stowage box
STROBE01/A	Amber Strobe, 15J, 220/240Vac, EEx (d) IIB+H2, T4, ATEX
ER2KITA	Installer's Kit including specified Ex d glands for areas not requiring IIC apparatus (x5), system grounding cable (x3) and enclosure lid handles
VESM01/E	M01 Retractable Cable reel with 15m (50 ft) of 2 conductor Hytrel protected static grounding cable

* Additional Options Available

The Earth-Rite PLUS forms part of the Earth-Rite range of Static Grounding and Bonding Equipment available from Newson Gale



Leading the way in hazardous area static control

www.newson-gale.com

Newson Gale Inc
460 Faraday Avenue
Unit B, Suite 1
Jackson, NJ 08527
USA

Tel: +1 732 987 7715
Fax: +1 732 791 2182

Email: groundit@newson-gale.com

Newson Gale Ltd
Omega House
Private Road 8
Colwick, Nottingham
NG4 2JX, UK

Tel: +44 (0)115 940 7500
Fax: +44 (0)115 940 7501

Email: groundit@newson-gale.co.uk